

# PADDLE TYPE FLOW SWITCH

Flow Switch utilizes the force of liquid flow to propel its paddle in order to detect the incoming flow or moving of the existing liquid in pipe. In condition of static liquid or no liquid, the spring is in expanding and press the magnet downward vertically. Reed switch contact is N.O.

As flow occurs and the paddle is thrust and raised at an upward angle of 20°~30° (or more), the eccentric of paddle will push the magnet upward to actuate the reed switch which is thus in a close circuit. The length of paddle can be adjusted with the diameter of a pipe.

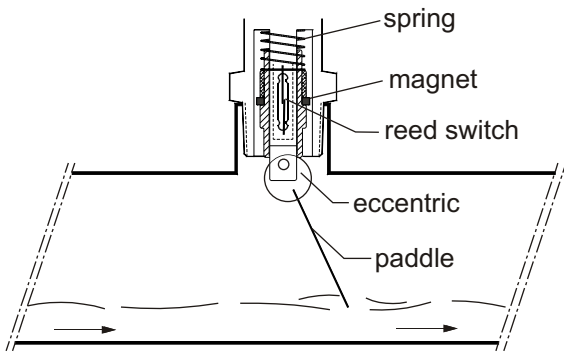

Switch on in case of liquid flowing in pipes

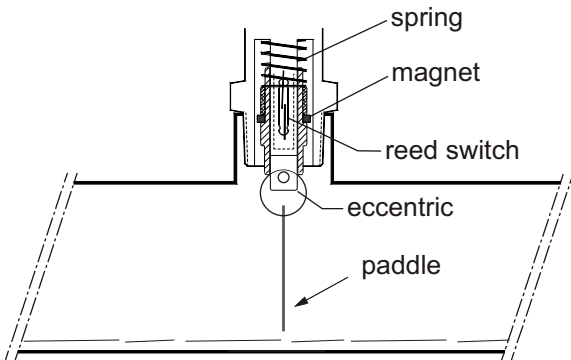

Switch off in case of no moving liquid in pipes

## CONFIGURATION CUTTING DRAWINGS

1. O-Ring
2. Paddle
3. Eccentric
4. Reed switch
5. Spring
6. Magnet
7. Housing
8. Screw
9. Center rod

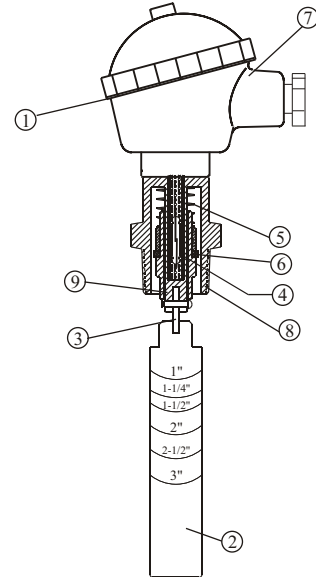

NEPSI

MODEL: SF1710

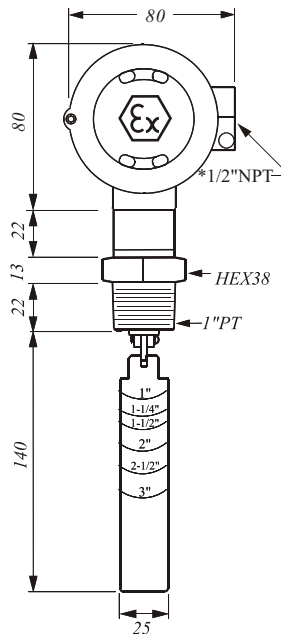

MODEL: SF1800

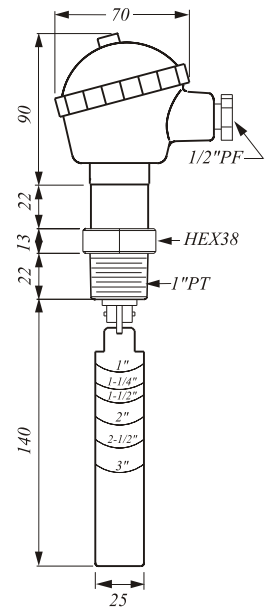

\*Optional part 1/2" NPT

used for SF1710



Spec.	Model	SF1710	SF1800
Housing Material		Aluminum Alloy, Ex d IIC T6	Aluminum Alloy, IP65
Operation Temp.		-30°C~100°C	-30°C~150°C
Paddle Material		SUS304	SUS304
Operation Pressure		Max. 355 PSIG	Max. 355 PSIG
Pressure Drop Allowance		3 PSIG	3 PSIG
Set Point Tolerance		± 25%	± 25%
Repeatability Tolerance		± 5%	± 5%
Contact Capacity		60W 220Vac/200Vdc, SPDT	60W 220Vac/200Vdc, SPDT

**FLOW CONTROL RANGE TABLE**

Paddle Length	1"		1-1/4"		1-1/2"		2"		2-1/2"		3"	
	Act.	De-Act.	Act.	De-Act.	Act.	De-Act.	Act.	De-Act.	Act.	De-Act.	Act.	De-Act.
1"	5	4	8.5	6.5	12	9	17	15				
1-1/4"			6.5	4.5	9	7	15	12	23	20		
1-1/2"					14	10	23	16	32	25		
2"							18	12	24	17	33	27
2-1/2"									20	13	27	22
3"											22	16

**INSTALLATION**

1. Paddle length established approximate actuation setting of a Flow Switch unit. Paddle length is decided according to the lowest point of paddle while actuating the reed switch and the diameter of the pipe. Cut off the paddle at proper pipe size mark or wherever desired but not less than 1" left.
  2. The paddle must be parallel to the cutting face of a pipe and the mounting screw is 1" NPT.
  3. The FLOW mark on the screw hexagon must be parallel to the pipe and the ground.
  4. Before installing the unit to a tee pipe, be sure to apply tape seal to the screw then tighten up.
- It is not recommended to the 1" NPT plastic pipe.

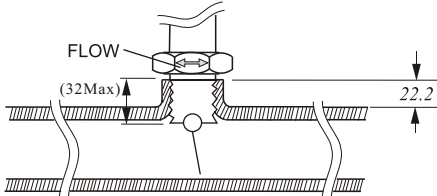

**CAUTION**

1. The pressure and temperature ranges as shown in the catalog, must not be exceeded and also take the abrupt pressure and temperature into considerations.
2. Operating temperature changes do affect switch set points. In case of the liquid temperature would vary with the specific gravity changes during processing, please contact us for assistance.
3. The flow switch is designed for shock and vibration resistance. However, shock and vibration should be as minimized as possible.
4. Excessive contamination in fluid might inhibit Paddle operation, occasional wipe-down would be necessary.
5. Electrical entry and mounting require sealing from moisture.